

DECLARATION OF PERFORMANCE

DoP 0248

for fischer termoz PN 8 (Plastic anchors for use in concrete and masonry)

EN

1. <u>Unique identification code of the product-type:</u>	DoP 0248	
2. <u>Intended use/es:</u>	Nailed-in plastic anchor for fixing of external thermal insulation composite systems (ETICS) with rendering in concrete and masonry, See appendix, especially annexes B1- B3.	
3. <u>Manufacturer:</u>	fischerwerke GmbH & Co. KG, Weinhalde 14-18, 72178 Waldachtal, Germany	
4. <u>Authorised representative:</u>	-	
5. <u>System/s of AVCP:</u>	2+	
6. <u>European Assessment Document:</u>	ETAG 014, Edition February 2011, used as EAD	
European Technical Assessment:	ETA-09/0171; 2016-03-18	
Technical Assessment Body:	DIBt- Deutsches Institut für Bautechnik	
Notified body/ies:	2873 TU Darmstadt	
7. <u>Declared performance/s:</u>		
Safety in use (BWR 4)		
Characteristic load bearing capacity:	Characteristic resistance under tension load:	Annex C1
	Minimum edge distance:	Annex B2
	Minimum spacing:	Annex B2
Displacements:	Tension load with partial factor:	Annex C2
	Displacements:	Annex C2
Plate stiffness:	Diameter of the anchor plate:	Annex C2
	Load resistance of the anchor plate:	Annex C2
	Plate stiffness:	Annex C2
Energy economy and heat retention (BWR 6)		
Thermal transmittance:	Point thermal transmittance of an anchor:	Annex C2
	Insulating layer thickness of the ETICS:	Annex C2
8. <u>Appropriate Technical Documentation and/or Specific Technical Documentation:</u>	-	

The performance of the product identified above is in conformity with the set of declared performance/s. This declaration of performance is issued, in accordance with Regulation (EU) No 305/2011, under the sole responsibility of the manufacturer identified above.

Signed for and on behalf of the manufacturer by:



Dr. Oliver Geibig, Managing Director Business Units & Engineering
Tumlingen, 2021-01-08



Jürgen Grün, Managing Director Chemistry & Quality

This DoP has been prepared in different languages. In case there is a dispute on the interpretation the English version shall always prevail.

The Appendix includes voluntary and complementary information in English language exceeding the (language-neutrally specified) legal requirements.

Specific Part

1 Technical description of the product

The fischer nailed-in anchor termoz PN 8 consists of a plastic sleeve made of polypropylene, a plate and an accompanying specific nail made of glass fibre reinforced polyamide.

The anchor may in addition be combined with the anchor plates DT 90, DT 110 and DT 140.

The Product description is given in Annex A.

2 Specification of the intended use in accordance with the applicable European Assessment Document

The performances given in Section 3 are only valid if the anchor is used in compliance with the specifications and conditions given in Annex B.

The verification and assessment methods on which this European Technical Assessment is based lead to the assumption of a working life of the anchor of at least 25 years. The indications given on the working life cannot be interpreted as a guarantee given by the producer, but are to be regarded only as a means for choosing the right products in relation to the expected economically reasonable working life of the works.

3 Performance of the product and references to the methods used for its assessment

3.1 Mechanical resistance and stability (BWR 1)

The essential characteristics regarding mechanical resistance and stability are included under the Basic Works Requirement Safety in use.

3.2 Hygiene, health and the environment (BWR 3)

Regarding dangerous substances there may be requirements (e.g. transposed European legislation and national laws, regulations and administrative provisions) applicable to the products falling within the scope of this European Technical Assessment. In order to meet the provisions of Regulation (EU) No 305/2011, these requirements need also to be complied with, when and where they apply.

3.3 Safety in use (BWR 4)

Essential characteristic	Performance
Characteristic tension resistance	See Annex C 1
Edge distances and spacing	See Annex B 2
Point thermal transmittance	See Annex C 2
Plate stiffness	See Annex C 2
Displacements	See Annex C 2

4 Assessment and verification of constancy of performance (AVCP) system applied, with reference to its legal base

In accordance with guideline for European technical approval ETAG 014, February 2011 used as European Assessment Document (EAD) according to Article 66 Paragraph 3 of Regulation (EU) No 305/2011 the applicable European legal act is: 97/463/EC.

The system to be applied is: 2+

termoz PN 8

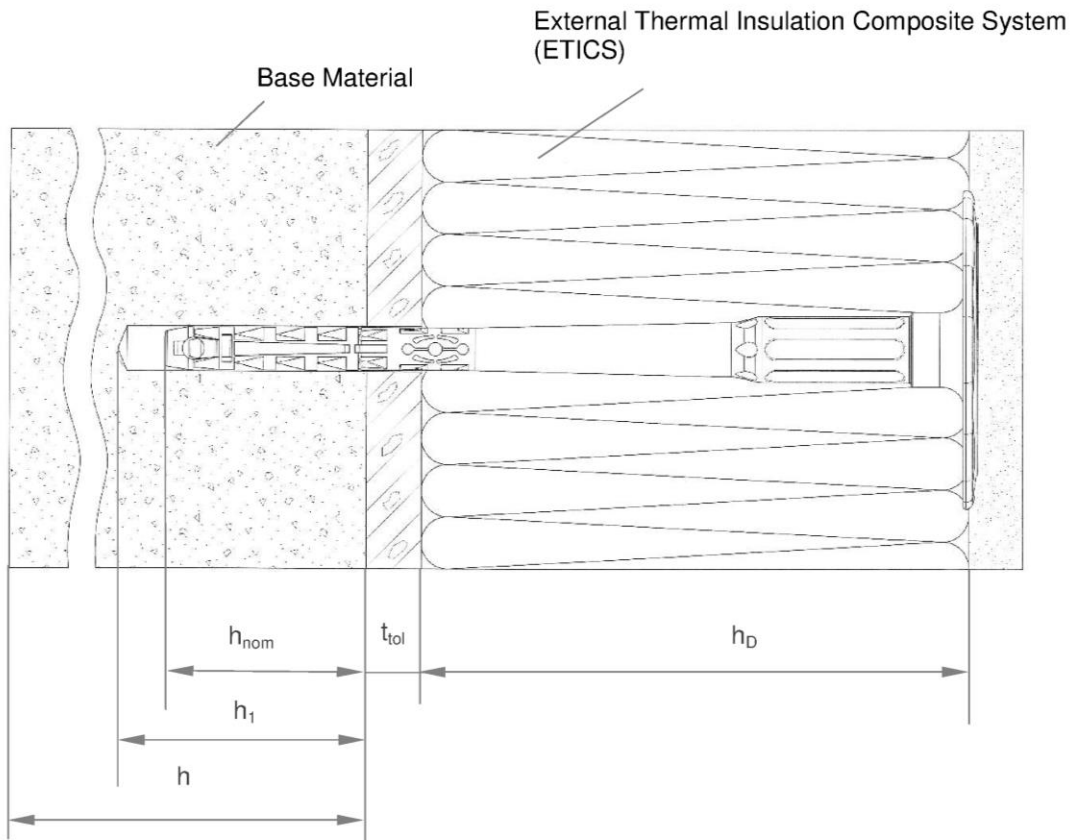

Legend

- h_{nom} = Overall plastic anchor embedment depth in the base material
- h_1 = Depth of drilled hole to deepest point
- h = Thickness of member (wall)
- h_D = Thickness of insulation material
- t_{tol} = Thickness of equalizing layer or non-load bearing coating

fischer termoz PN 8

Product description
Installed anchor

Annex A1
Appendix 3 / 10

termoz PN 8

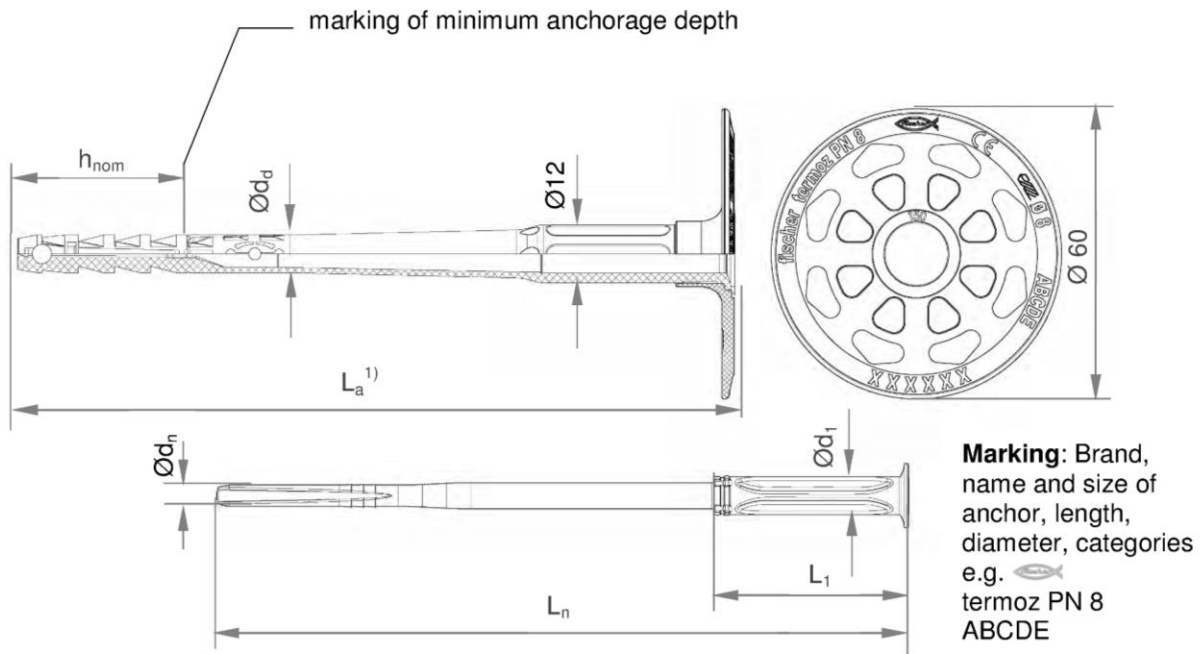

¹⁾ Various length of the anchors are possible

Table A2.1: Dimensions

Anchor type	Anchor sleeve		Accompanying specific plastic nail		
	Ø d _d [mm]	h _{nom} [mm]	Ø d _n [mm]	L ₁ [mm]	Ø d ₁ [mm]
termoz PN 8	8	35/55 ¹⁾	4,4	40	8

¹⁾ Only for use Cat. D and E

Determination of maximum thickness of insulation: $h_D = L_a - h_{nom} - t_{tol}$

e.g. for termoz PN 8x150:

$L_a = 148 \text{ mm}$, $h_{nom} = 35 \text{ mm}$, $t_{tol} = 10$

$h_D = 148 - 35 - 10 \approx 100 \text{ mm}$

termoz PN 8 :

$L_{a \min} \geq 110 \text{ mm}$; $L_{a \max} \leq 230 \text{ mm}$

$L_a = \text{length of accompanying specific nail } L_n + 5 \text{ mm}$

fischer termoz PN 8

Product description
Dimensions

Annex A2

Appendix 4 / 10

Table A3.1: Material

Designation	Material
Anchor sleeve	PP, colour: grey
Specific plastic nail	PA 6 GF, colour: nature
Slip-on plate	PA6, GF colour: grey, orange, red, green, yellow, blue

Drawing of the slip-on plates

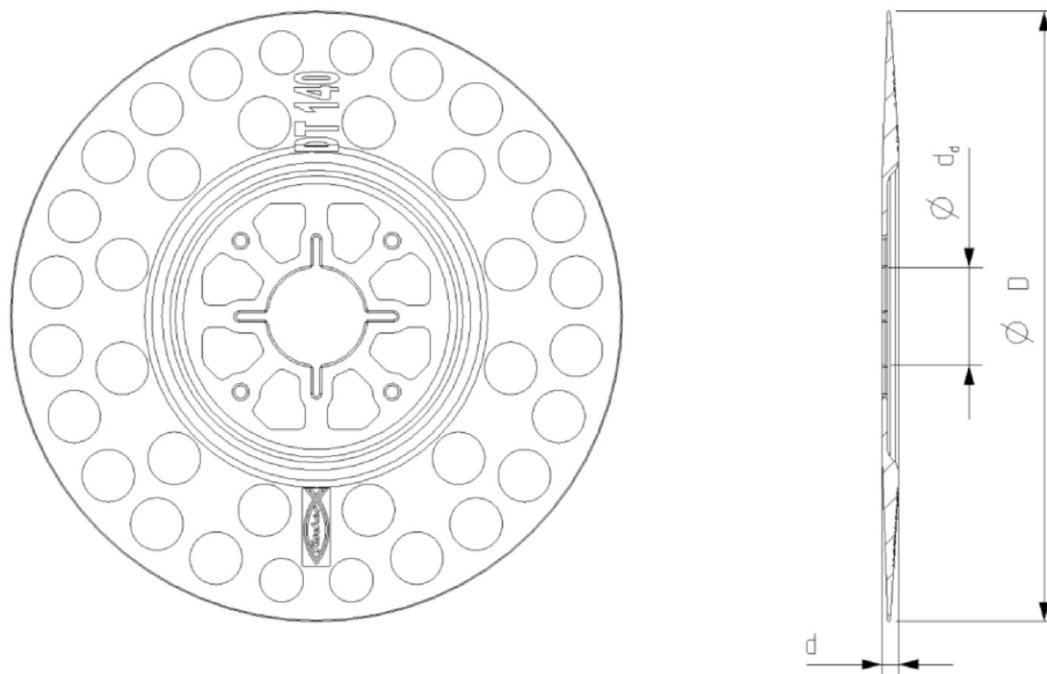

Table A3.2 Slip-on plates, diameters and material

Slip-on plate	Ø D [mm]	Ø d _d [mm]	d [mm]	Material
DT 90 / 110 / 140	90 / 110 / 140	22,5	3,9	PA 6 GF

fischer termoz PN 8

Product description

Material
Slip-on plates combined with termoz PN 8

Annex A3

Appendix 5 / 10

Specifications of intended use

Anchorage subject to:

- The anchor may only be used for transmission of wind suction loads and shall not be used for the transmission of dead loads of the external thermal insulation composite system (ETICS).

Base materials:

- Normal weight concrete (use category A) according to Annex C1.
- Solid masonry (use category B), according to Annex C1.
- Hollow or perforated masonry (use category C), according to Annex C1.
- Lightweight aggregate concrete (use category D), according to Annex C1.
- Autoclaved aerated concrete (use category E), according to Annex C1.
- For other base materials of the use categories A, B, C, D and E the characteristic resistance of the anchor may be determined by job site tests according to ETAG 014 Edition February 2011, Annex D.

Temperature Range:

- 0°C to +40°C (max. short term temperature +40°C and max. long term temperature +24°C).

Design:

- The anchorages are designed in accordance with ETAG 014 Edition February 2011 under the responsibility of an engineer experienced in anchorages and masonry work.
- Verifiable calculation notes and drawings are prepared taking account of the loads to be anchored. The position of the anchors is indicated on the design drawings.
- Fasteners are only to be used for multiple fixings of ETICS.

Installation:

- Drilling method according to Annex C1.
- Anchor installation carried out by appropriately qualified personnel and under the supervision of the person responsible for technical matters on the site.
- Installation temperature from 0°C to +40°C
- Exposure to UV due to solar radiation of the anchor not protected by rendering ≤ 6 weeks.

fischer termoz PN 8

Intended use
Specification

Annex B1

Appendix 6 / 10

Table B2.1: Installation parameters

Anchor type			termoz PN 8
Drill hole diameter	d_0	= [mm]	8
Cutting diameter of drill bit	d_{cut}	≤ [mm]	8,45
Depth of drilled hole to deepest point	h_1	≥ [mm]	45/65 ¹⁾
Overall plastic anchor embedment depth in the base material	h_{nom}	≥ [mm]	35/55 ¹⁾

¹⁾ Only for use categorie "D" and "E"

Table B2.2: Minimum distances and spacings

			termoz PN 8
Minimum thickness of member	h	≥ [mm]	100
Minimum spacing	s_{min}	= [mm]	100
Minimum edge distance	c_{min}	= [mm]	100

Scheme of distance and spacing

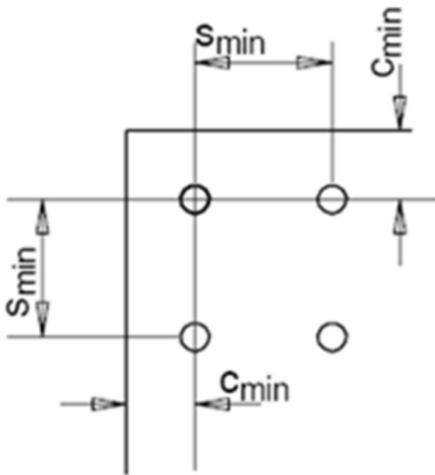

fischer termoz PN 8

Intended use

Installation parameters
Minimum distances and spacings

Annex B2

Appendix 7 / 10

Installation instructions

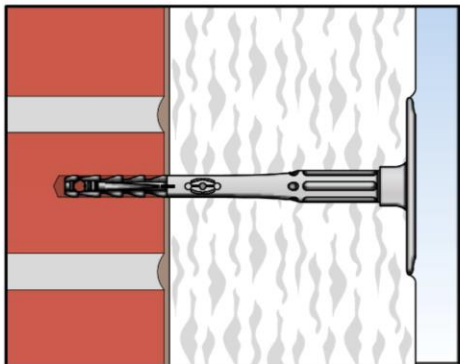
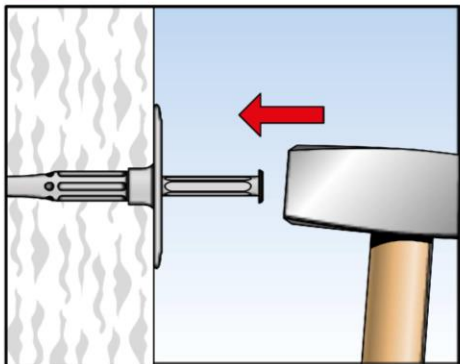
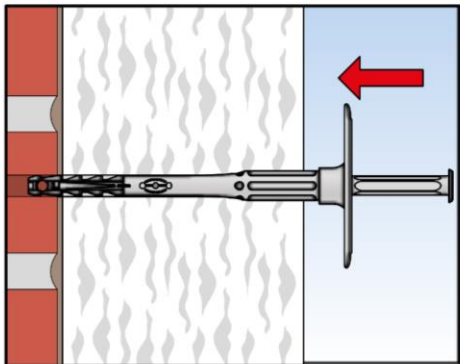
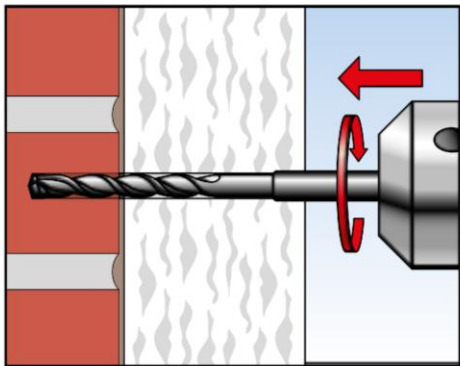

1. Drill hole by corresponding drilling method.

2. Insert anchor manually.

3. Set anchor by hammer-blows.

4. Correctly installed anchor.

fischer termoz PN 8

Intended use
Installation instruction

Annex B3

Appendix 8 / 10

Table C1.1: Characteristic resistance N_{Rk} in [kN] to tension loads for single anchor

Base material	Use cat. ¹⁾	Bulk density class ρ [kg/dm ³]	Min. compressive strength f_b [N/mm ²]	Remarks	Drill method ²⁾	Characteristic resistance N_{Rk} to tension loads [kN] termoz PN 8
Concrete \geq C12/15 - C50/60 EN 206:2013	A	-	-	-	H	0,5
Solid Clay bricks e.g. acc. to DIN 105-100:2012-01, EN 771-1:2011, Mz	B	$\geq 2,0$	12	Cross section reduced up to 15% by perforation vertically to the resting area	H	0,6
Calcium silicate solid bricks, e.g. acc. to DIN V 106:2005-10, EN 771-2:2011, KS	B	$\geq 1,8$	12	Cross section reduced up to 15% by perforation vertically to the resting area	H	0,6
Vertically perforated clay bricks e.g. acc. to DIN 105-100:2012-01, EN 771-1:2011, HLz	C	$\geq 1,0$	12	Cross section reduced between 15% and 50% by perforation vertically to the resting area. Exterior web thickness ≥ 12 mm	R	0,4
Hollow calcium silicate brick, e.g. acc. to DIN V 106:2005-10, EN 771-2:2011, KSL	C	$\geq 1,4$	12	Cross section reduced between 15% and 50% by perforation vertically to the resting area. Exterior web thickness ≥ 23 mm	H	0,4
Lightweight concrete hollow blocks e.g. acc. to DIN V 18151-100:2005-10, EN 771-3:2011, Hbl	C	$\geq 1,2$	10	-	H	0,5
Lightweight aggregate concrete, LAC e.g. acc. to EN 1520:2011	D	$\geq 0,9$	4	Minimum solid brick or minimum exterior web thickness $t = 50$ mm	H	0,3
			6			0,4
Autoclaved aerated concrete blocks, AAC e.g. acc. to DIN V 4165-100:2005-10, EN 771-4:2011	E	$\geq 0,5$	4	-	R	0,3
		$\geq 0,6$	6			0,4
Partial safety factor for anchor resistance ³⁾					Y_M	2,0

1) See Annex B 1

2) R = Rotary drilling | H = Hammer drilling

3) In absence of other national regulations

fischer termoz PN 8

Performance
Characteristic resistance

Annex C1

Appendix 9 / 10

Table C2.1 Point thermal transmittance acc. to EOTA Technical Report TR 025:2007-06

Anchor type	Thickness of insulation material h_D [mm]	Point thermal transmittance χ [W/K]
termoz PN 8	60 - 180	0,000

Table C2.2: Plate stiffness acc. to EOTA Technical Report TR 026:2007-06

Anchor type	Max. size of the anchor plate [mm]	Load resistance of the anchor plate [kN]	Plate stiffness [kN/mm]
termoz PN 8	60	1,7	0,6

Table C2.3 Displacements

Base material	Tension load F_{Rd} [kN]	Displacements δ_m [mm]
Concrete \geq C12/15 – C50/60 acc. to EN 206:2013	0,15	0,2
Clay brick e.g. acc. to DIN 105-100:2012-01, EN 771-1:2011, Mz 12	0,20	0,2
Calcium silicate solid bricks e.g. acc. to DIN V 106:2005-10 EN 771-2 :2011,KS 12	0,20	0,3
Vertically perforated clay brick e.g. acc. to DIN 105-100:2012-01 EN 771-1:2011,Hlz 12	0,15	0,4
Hollow calcium silicate brick e.g. acc. to DIN V 106:2005-10 EN 771-2:2011, KSL 12	0,15	0,2
Hollow brick lightweight concrete e.g. acc. to DIN V 18153-100: 2005-10, EN 771-3:2011, Hbl 4	0,15	0,2
Lightweight aggregate concrete e.g. acc. to EN 1520:2011	LAC 4	0,2
	LAC 6	
Autoclaved aerated concrete blocks e.g. acc. to DIN V 4165-100:2005-10 EN 771-4	AAC 4	0,1
	AAC 6	0,2

fischer termoz PN 8**Performance**Point thermal transmittance | Plate stiffness
Displacements**Annex C2**

Appendix 10 / 10